

# A200

Enjoyment through perfection



MAKE IT  
*Wonderful!*

**FRANKE**

# THE ESSENCE OF PERFECTION

For us at Franke, enjoyment means perfect coffee prepared with ease. With the A200, we have created a coffee machine that embodies this perfectly.

As always, the first impressions are with the eye. This is then confirmed by the all-round sensual experience – everything has a high-quality feel, just as it should. Operation follows an intuitive logic that makes putting the A200 into service child's play. Even the mechanical sound of the ceramic bean grinder builds confidence. Then comes the aroma of freshly brewed coffee! This is followed by the first sip of the perfect crema and the rediscovery of an authentic aroma. This machine is a Franke from start to finish!







Espresso



Kaffee Crème



Cappuccino



Milchkaffee



Latte Macchiato



Tee

**FRANKE**

# ENJOYMENT

## YOU CAN ALWAYS COUNT ON

The A200 was designed so it can be put into service and operated without reading a manual – simply plug in and away you go! This is a masterpiece of Swiss engineering that makes everyday handling of the A200 refreshingly simple.

### Simple yet customizable operation

The A200 invites you to define as many as 18 products and then save them in the menu. In doing so, you first specify in detail how you would like the beverage to be prepared. Should it use the Ethiopian wild coffee from the grinder on the left, or your favorite Ecuadorian arabica from the grinder on the right? Should the brewing period be slightly longer or shorter? Would you like to add a little more or less milk? Secondly, you then decide in which sequence your beverages are arranged in the menu so that your favorites appear at the very top. The A200 guides you through this configuration with simple, intuitive steps. The process is simple and customizable.

### A new standard of convenience

The qualities of the A200 reveal themselves impressively in everyday professional use. Take the cleaning concept, for example. Here, the display guides you through the cleaning procedure using illustrations of the machine and simple prompts. While the detailed instructions show what to do image by image, experienced users can run through the program efficiently in just a few steps. This all takes just a few minutes – without any manual or introduction – and can be carried out without any prior knowledge.



After a product has been selected, you define the desired coffee roasting (left or right grinder, or the powder dosing system).



Total control at a glance with the fill level display and maintenance instructions.



The cleaning process is represented pictorially step by step.

# WELL THOUGHT OUT DOWN TO THE FINEST DETAIL

STANDBY TIMER, OPTIMIZED  
POWER CONSUMPTION

STEAM SPOUT

HEIGHT-ADJUSTABLE BEVERAGE SPOUT  
WITH INTEGRATED HOT WATER, EASY TO CLEAN  
THANKS TO THE MAGNETIC CASING

DRIP TRAY (2.4 LITER) WITH  
FILL LEVEL MONITORING



**OPTIONAL CAPSULE BREWING UNIT  
FOR ADDED BEVERAGE DIVERSITY**



**GENEROUSLY SIZED BEAN HOPPER,  
EASILY ACCESSIBLE, SIMPLE TO REFILL**

**TWO PRECISION BEAN GRINDERS  
WITH CERAMIC BURRS**



**WATER TANK (4 LITER),  
EASY TO ACCESS FROM THE  
FRONT; PERMANENT WATER  
SUPPLY CONNECTION (OPTIONAL)**

# THE ENGINEERING OF ENJOYMENT

The A200 components work together seamlessly to ensure optimal enjoyment. Every detail has been designed and redesigned by our developers before being integrated optimally into the overall machine concept.

This starts with the generously sized bean hopper – a feat of engineering all on its own. It is unlocked using the central locking mechanism and simultaneously sealed at the bottom. It can now be removed with ease for cleaning or simply refilling with beans. The cover features a silicon sealing rim to protect the refined aroma of the beans, and is also available with a lock.

To achieve perfect coffee enjoyment, the A200 is shipped from the factory with two ceramic bean grinders whose coarseness can be set simply yet precisely. The two rotary controls are located underneath the bean hopper and are thus readily accessible and easy to adjust.

The machine's brewing unit is directly accessible from the side and can be removed effortlessly without any tools. Cleaning and maintenance are now a breeze.

A practical capsule brewing unit is optionally available for the clean, simple preparation of chocolate beverages.

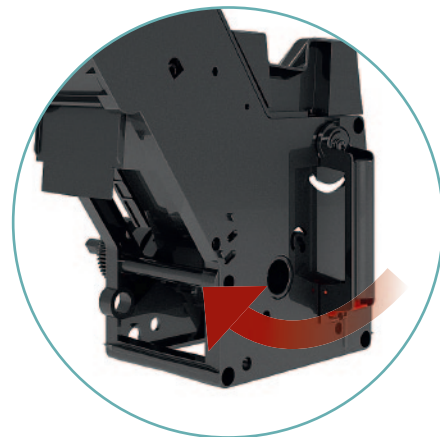

Can be removed with just one turn of the hand

**PRECISION BEAN GRINDER WITH DURABLE CERAMIC BURRS**

**BEAN HOPPER**

**CAPSULE BREWING UNIT**

**BREWING UNIT**



# SIMPLE HANDLING FOR MAXIMUM HYGIENE

The A200 has a seamless connection to yet another Franke innovation – the FoamMaster™. With this advanced milk system, you can set the foam consistency for specific beverages. Thanks to the high-precision measuring and control of the milk temperature – using a temperature sensor located directly in the milk container – an unmatched consistent quality of the milk foam is guaranteed.

## **A new standard of convenience**

The FoamMaster™ also stands out from the crowd with its advanced integrated cleaning concept. It reduces effort to a minimum and guarantees clean, safe handling. Spilled milk or cleaning agent is now a thing of the past. The cleaning container is installed in place of the milk container. The cleaning process runs fully independently and the machine returns automatically to Standby mode when finished. You can now take a break without any worries!

## **Hygienic, practical milk container system**

- Hose-free docking system for the milk container
- Integrated sensor for efficiently measuring the milk temperature
- Integrated cleaning cartridge

## **Efficient cleaning process**

- Automated process with integrated cleaning cartridge
- Safe and practical thanks to a separate cleaning container
- Highest level of cleanliness thanks to specially developed milk and coffee cleaning agents
- Maximum convenience: the cleaning process is ended automatically by the machine
- Conforms to HACCP

**FOAMMASTER™  
ON/OFF SWITCH**

**MILK CONTAINER (5 LITER) WITH INTEGRATED  
TEMPERATURE SENSOR AND DOCKING SYSTEM**

**MILK TEMPERATURE  
DISPLAY**

**LOCKABLE**



**CLEANING CONTAINER WITH  
INTEGRATED DOCKING SYSTEM**



**THE CLEANING AGENT CARTRIDGE**

# ENJOYMENT IS WHEN EVERYTHING IS JUST RIGHT

The A200 will enchant you with countless different possibilities. Enjoy your own beverage creations each and every day at the same high quality, and experience with all the senses the true meaning of quality at Franke.

#### **Coffee in consistently high barista quality**

- Perfect crema
- Two types of beans for added enjoyment
- Uniform quality in each and every cup

#### **Unique milk foam**

- Hand-made or automatic foam production
- Individually adjustable foam consistency
- The perfect final touch for any beverage creation

#### **Varieties of chocolate**

- Enticing chocolaty taste, loved by young and old alike
- Simple preparation using chocolate capsules

#### **Hot water for tea**

- Programmable filling level
- Also suitable for large cups thanks to the height-adjustable spout



# EVERYTHING FOR YOUR INDIVIDUAL NEEDS



## MILK SYSTEMS

- FoamMaster™ (FM)\*: hot and cold milk and milk foam, individually adjustable consistency, integrated cleaning system
- Milk system (MS): hot milk/milk foam

## A200 OPTIONS

- Lockable bean hopper
- Capsule brewing unit (for chocolate)
- Permanent water supply connection
- Coffee grounds ejector
- M2M/telemetry
- Billing systems
- Raised feet (100 mm)

## CUP WARMER

With four heatable trays

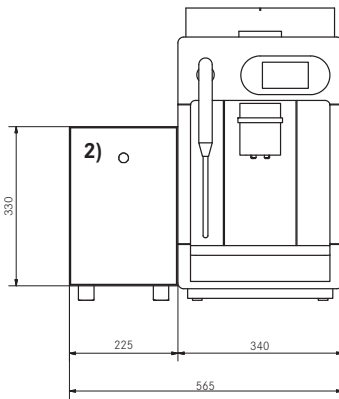
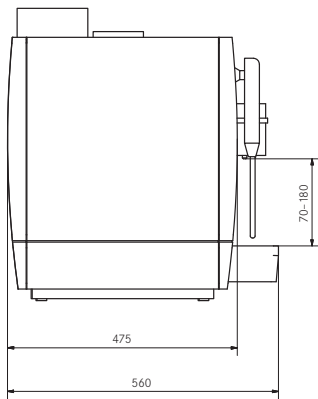
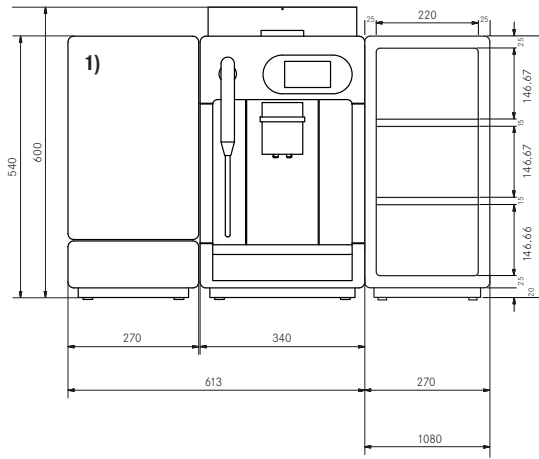

PRODUCT SPECIFICATIONS	A200 MS	A200 FM
Ristretto   Espresso	✓	✓
Coffee   Café crème	✓	✓
Cappuccino   Latte macchiato	✓	✓
Chococcino	✓	✓
Chocolate	✓	✓
Hot milk	✓	✓
Hot milk foam	✓	✓*
Cold milk		✓
Cold milk foam		✓*
Hot water	✓	✓
Steam	✓	

\* Licensed by Thermoplan

#### MACHINE MODELS

MODEL	ELECTRICAL CONNECTION	POWER
A200 MS	220-240 V 1LN PE 50/60Hz	2,4-2,75 kW
A200 FM	220-240 V 1LN PE 50/60Hz	2,4-2,75 kW

(other connection types upon request)

#### ACCESSORIES

A200 MS	ELECTRICAL CONNECTION	POWER
2) Refrigeration unit KE200 (4 l)	220-240 V 1LN PE 50/60Hz 10 A	82 W
Cup warmer (120 cups)	200-240 V 1LN PE 50/60Hz 10 A	120 W

A200 FM	ELECTRICAL CONNECTION	POWER
1) FoamMaster™ module (5l)	220-240 V 1LN PE 50/60Hz 10 A	1.95-2.3 kW
Cup warmer (120 cups)	200-240 V 1LN PE 50/60Hz 10 A	120 W

#### WATER CONNECTION (OPTIONAL)

Fixed water connection	Metal hose with union nut G 3/8", l = 1,5m (59")
Water supply line	If possible on installation side: untreated water (not from household decalcification system)
Water pressure	80 to 800 kPa (0.8 to 8.0 bar)
Water hardness	max. 70 mg CaO per liter of water (7 dH, 13 °fH)
Chloride content	max. 100 mg/l
Ideal pH value	7

#### WATER DRAIN (OPTIONAL)

Drain hose	Dia. = 16 mm, L = 2000 mm
------------	---------------------------





19'329'666/07.15/CH-EN Subject to dimensional, design and version changes.

Franke Kaffeemaschinen AG  
Franke Strasse 9  
4663 Aarburg  
Switzerland  
Fon +41 62 787 31 31  
[www.franke.com](http://www.franke.com)

Franke Coffee Systems GmbH  
Franke Strasse 1  
97947 Grünsfeld  
Germany  
Fon +49 9346 9278 0  
Fax +49 9346 9278 100  
[www.franke.de](http://www.franke.de)

Franke Coffee Systems  
UK Ltd  
18 Handley Page Way,  
Old Parkbury Lane,  
St Albans,  
Hertfordshire AL2 2DQ  
England  
Fon +44 1923 635700  
Fax +44 1923 635701  
[www.franke.com](http://www.franke.com)

Franke Japan Inc.  
Amflat, 12-35-12  
Nihonbashi Ningyocho, Chuo,  
Tokyo 103-0013  
Japan  
Fon +81 3 5642 5880  
[www.franke.com](http://www.franke.com)

Franke Coffee Systems  
Americas  
800 Aviation Parkway  
Smyrna, TN 37167  
USA  
Fon +1 615 462 4265  
Fax +1 615 462 4400  
[www.franke.com](http://www.franke.com)

**FRANKE**