

Evolution

Translation of Original Operating Instructions



Read the operating instructions and the chapter on safety information before operating the machine.
Keep the operating instructions near the machine.



COFFEE
SYSTEMS

Dear customer,

Congratulations on your purchase of an Evolution coffee machine.
Thank you for your confidence in us.

Evolution is a powerful and space-saving coffee machine. It adapts to your needs perfectly. Your customers will be impressed as you quickly prepare high-quality, customized coffee specialties.

We hope you enjoy your Evolution and that it will bring you consistently satisfied customers.

Sincerely, FRANKE Kaffeemaschinen AG

Table of Contents

EXPLANATION OF SYMBOLS	3	CLEANING AND RINSING	22
FOR YOUR SAFETY	4	OVERVIEW OF THE SEPARATE CLEANING INSTRUCTIONS	22
PROPER USE	4	CLEANING WATER AND STEAM NOZZLES	23
GENERAL SAFETY CONCERNS DURING USE	5	RINSING THE COFFEE AND MILK SYSTEMS MANUALLY	23
SCOPE OF DELIVERY AND IDENTIFICATION	7	CONFIGURING YOUR EVOLUTION	24
SCOPE OF DELIVERY	7	PRODUCT DEFINITION	25
IDENTIFICATION	9	SHUT-DOWN AND DISPOSAL	28
DESCRIPTION OF MACHINE	10	SHUT-DOWN FOR LONGER PERIODS AND STORAGE	28
EVOLUTION	10	DISPOSAL	28
INSTALLATION AND TECHNICAL DATA	12	TROUBLESHOOTING AND ERROR CODES	29
INSTALLATION	12	CERTIFICATIONS	31
DIMENSIONS	13	DECLARATION OF CONFORMITY	31
INSTALLATION DIMENSIONS	13	INDEX	32
COMMISSIONING, FILLING AND EMPTYING	15		
START-UP OF THE EVOLUTION	15		
START-UP OF THE REFRIGERATION UNIT (OPTIONAL)	17		
PREPARING DRINKS	19		
PREPARING A STANDARD DRINK	19		
PREPARING A DRINK WITH PRESELECTION	20		
HOT WATER DISPENSER	21		
STEAM WAND	21		

explanation of symbols



DANGER indicates potentially life-threatening danger or grave injury.



WARNING indicates risk of injury.



CAUTION indicates risk of minor injury.



NOTICE indicates possibility of damage to the machine.



Disinfecting a component.



This symbol indicates tips, shortcuts and additional information.

For Your Safety

Both you and the Evolution are important to us. Therefore, we would like to provide you with detailed safety information. For us, a high level of safety goes without saying. Protect yourself against remaining risks from use of the machine.

Proper use

Evolution

The Evolution is a coffee machine for use in food service, offices and similar environments. It is designed to process whole coffee beans. The various add-on units allow integrated processing of milk with the Evolution.

The Evolution is designed exclusively for preparing coffee drinks, milk combination drinks, hot water and steam in accordance with these instructions and the technical data.

Refrigeration Unit/Milk Systems (optional)

Milk systems are optional add-on units for Evolution coffee machines. They are to be used only to cool milk in conjunction with preparing coffee drinks with an Evolution coffee machine.

Only use pre-cooled milk (2-5°C or 36-41°F). Only use FRANKE cleaning solution. Other detergents may leave a residue in the milk system.

Cup Warmer (optional)

The cup warmer is an optional add-on unit for Evolution coffee machines. It is intended only for warming coffee cups and glasses used when preparing drinks.

The cup warmer is not designed to dry dish towels or other cloths. It is not necessary to cover the cups to warm them.

Important

Do not operate the Evolution and its add-on units until you have read and understood these instructions in full. Keep these instructions near your Evolution.

The Evolution coffee machine is intended for use by trained staff. Each operator of the Evolution must have read and understood these instructions. This does not apply to self-service customers. Self-service machines must always be monitored to protect the users.

Children or physically or mentally challenged persons must never approach the machine alone and must always be supervised.

Have the machine serviced at regular intervals. Regular maintenance will ensure the safe operation and high performance of your Evolution.

If the Evolution is sold or transferred to a third party, please give the operating instructions to the next user.



If you need more information or if specific problems occur that cannot be resolved using these instructions, contact your local customer service representative for the required information or contact FRANKE Kaffeemaschinen AG in Aarburg, Switzerland, directly.

General safety concerns during use

DANGER

Risk of death by electrocution!

- Never operate a machine that has been damaged or has a damaged power supply cable.
- If you suspect damage to the machine (for instance, a hot or burning odor), unplug the machine from the outlet and contact your service technician.

If the power supply cable to this machine is damaged, it must be replaced by a special power cord.

- Only a qualified service technician should replace the power supply cable.
- Ensure that the machine and power supply cable are not near any hot surfaces such as gas or electric stoves or ovens.
- Ensure that the power supply cable is not pinched and does not rub against sharp edges. The machine contains electrically conductive parts. Opening the machines can pose risk of death.
- Never open or attempt to repair the machine yourself.
- Do not make any modifications to the machine that are not described in the owner's manual.
- Repairs should only be made by a service technician using original replacement and add-on unit parts.

WARNING

Risk of injury, eye injury and damage to the machine!

Objects in the coffee bean hopper or grinder may splinter and be ejected, leading to damage to the machine or injury.

- Never put any objects in the coffee bean hopper or grinder.
- Never poke around in the coffee bean hopper or grinder with any object.

WARNING

Risk of injury!

Reaching into the Evolution may result in abrasions or injuries caused by crushing from interior components.

- Only open the Evolution when daily work requires it (to empty the grounds container).
- Exercise care and caution when working on an open Evolution.
- Only service personnel should open the Evolution for any other purpose.

⚠ WARNING**Risk of scalding!**

During automatic and manual cleaning, hot water and steam are released repeatedly.

- Keep hands away from the outlets and nozzles during cleaning!

When drinks are dispensed, the products themselves pose a risk of scalding.

- Always be careful with hot drinks!

⚠ WARNING**Risk of burns!**

The coffee and milk dispensers, hot water nozzle and steam dispenser are hot.

- Do not touch the outlets or nozzles.

The surfaces of the cup warmer are hot.

- Do not touch these surfaces.

⚠ CAUTION**Risk of spoiled food residue!**

If the machine is not cleaned regularly, milk, powder, syrup and coffee residue may accumulate in the machine, clog the outlets or find its way into drinks.

- Clean the Evolution and its add-on units at least once a day.
- Read the chapter "Cleaning and Rinsing."

NOTICE**Damage from foreign objects!**

Putting foreign objects through the powder lid can lead to damage to the machine.

- Never insert any foreign objects.
- Never poke around in the powder lid with any object and never insert anything except cleaning tablets or ground coffee.

NOTICE**Damage to the machine!**

- Install the machine out of the reach of children.
- Do not expose the machine to the elements, such as rain, frost or direct sunlight.

The power supply cable may pose the risk of tripping or become damaged.

- Never let the power supply cable hang loose.

NOTICE**Damage from water jets!**

The Evolution is not protected against water jets.

- Do not use water jets or high-pressure cleaners to clean the machine.
- Read the chapter "Cleaning and Rinsing."

Scope of Delivery and Identification

The Evolution is a powerful coffee machine.

Listed below are ways to identify your machines and what is included in the standard delivery.

Scope of delivery



Evolution

Basic model. Optional add-on units can be ordered from your FRANKE retailer.



Cleaning tablets

To clean and protect your coffee system.

Item no: BK 300 935



Cleaning solution (optional)

To keep your milk system clean and hygienic.

Item no: BK 301 732



Cleaning brush

To clean the brewing unit.

Item no: 1L 301 160



Cleaning brushes (optional)

To clean the dispenser system.

Item no: 1L 301 376



Adjust card

To program the machine and back up data.

Item no: 10 300 924



Owner's manual

Operating instructions

Item no.: 1T 312 563

Also refer to the chapter "Cleaning and Rinsing."

Other manuals can be downloaded via the Internet.
www.franke.com



The configuration of your Evolution may differ from that shown in the instructions. Please refer to your purchase agreement.

Additional accessories may be obtained directly from your retailer or from FRANKE Kaffeemaschinen AG in Aarburg, Switzerland.

Identification

Evolution type plate

FRANKE Franke Kaffeemaschinen AG
 Franke-Strasse 9
 CH - 4663 Aarburg
 Schweiz

COFFEE SYSTEMS

Name: Evolution
 Seriennr: 12345678
 Inst. Nr: 466xxx
 App. Nr: 3x.9.0.xxxx
 Typ: E xM H D xx xx
 Spannung: 400 V 2L N PE
 Frequenz: 50 / 60 Hz
 Leistung: 5200 W
 Absicherung: 16 A
 Wasserdruck: 0.8MPa

Boiler:	Kaffee	Tee/Dampf
Wasserinhalt:	1.2l	1.6l
Betriebsdruck:	1000kPa	200kPa

CE UL NSF

- Manufacturer
- Identification code
- Model (for model codes, see below)
- Apparatus number
- Refrigerant
- Electrical data
- Boiler performance data

Refrigeration unit type plate (as an example for add-on units)

CE **FRANKE**

Kaffeemaschinen AG
 CH-4663 Aarburg

Inst. Nr: AK4-xxx xxx
 Typ: KE 320
 App. Nr: 39.0000.00001

Kältemittel: R134a
 Kältemittelmenge: 40 g
 Stromaufnahme: 0.72 A
 Spannung (Klimazone N): 200 - 240 V~
 Spannung (Klimazone T): 220 - 240 V~
 Frequenz: 50 Hz
 Absicherung: 10 A

Position of the type plates



Model code

Model code	Component
E	Evolution
E II	Evolution Top
2M	Number of grinders (max. 2)
H	Hot water dispenser
D	Steam dispenser
CF	Milk foam, warm and cold milk
KE	Refrigeration unit (optional)
TW	Cup Warmer (optional)

Description of machine

You have chosen enjoyment of every single coffee with the Evolution. In this section you will learn more about the functions and options of your Evolution and where the controls are located.

Evolution

The Evolution has numerous options. To give you an overview of your machine, we will illustrate various options with a sample configuration.

You will become familiar with the Evolution and its controls as well as the refrigeration unit and cup warmer.

Please note that your Evolution may look different from the configuration shown here.

Evolution capacity

Specialty	Hourly capacity of Evolution*
Espresso	180 cups
Café crème	120 cups
Cappuccino	120 cups
Latte macchiato	120 cups
Warm milk	120 cups
Cold milk	150 cups
Hot water	20 liters (5.28 gallons)

* The hourly capacity is a theoretical value and depends on the configuration of the machine(s) and the size of the drinks. Because of its innovative milk system, the Evolution with Foam Master has a much higher hourly capacity for milk than the Evolution. Your sales representative will be glad to help you.

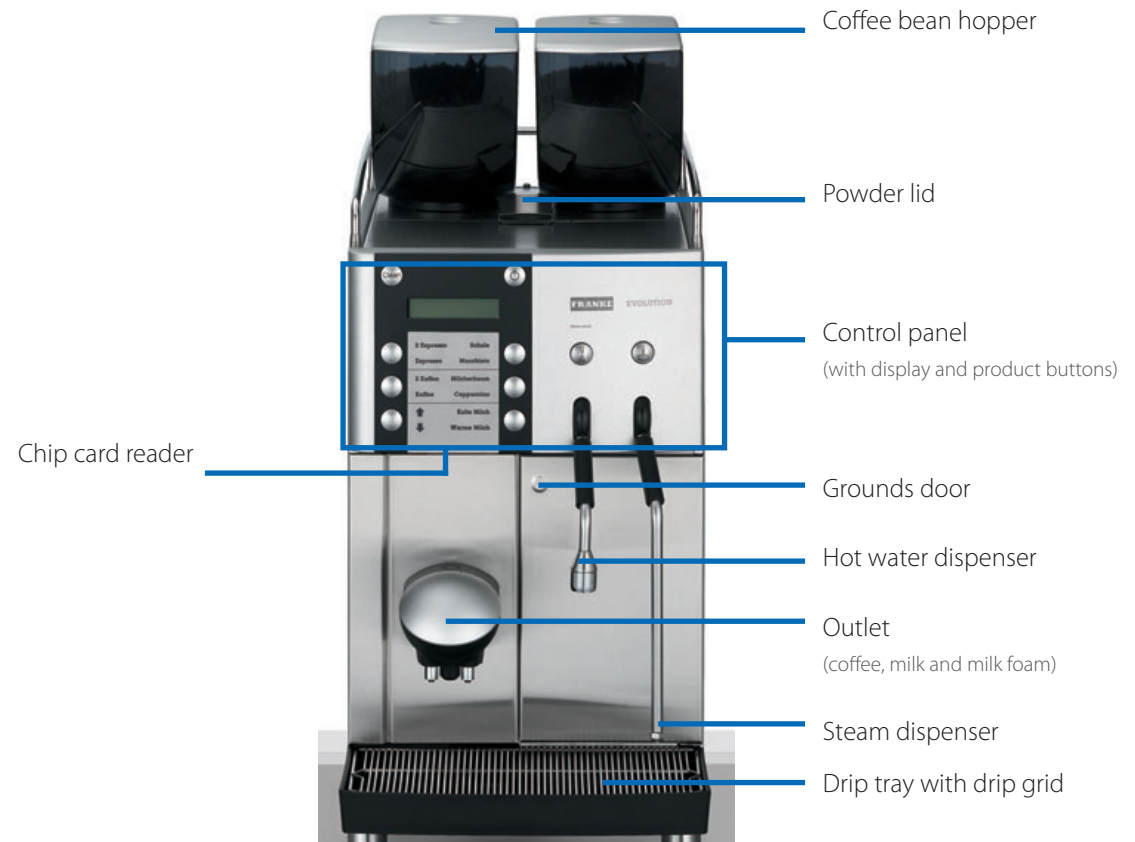

Evolution control panel

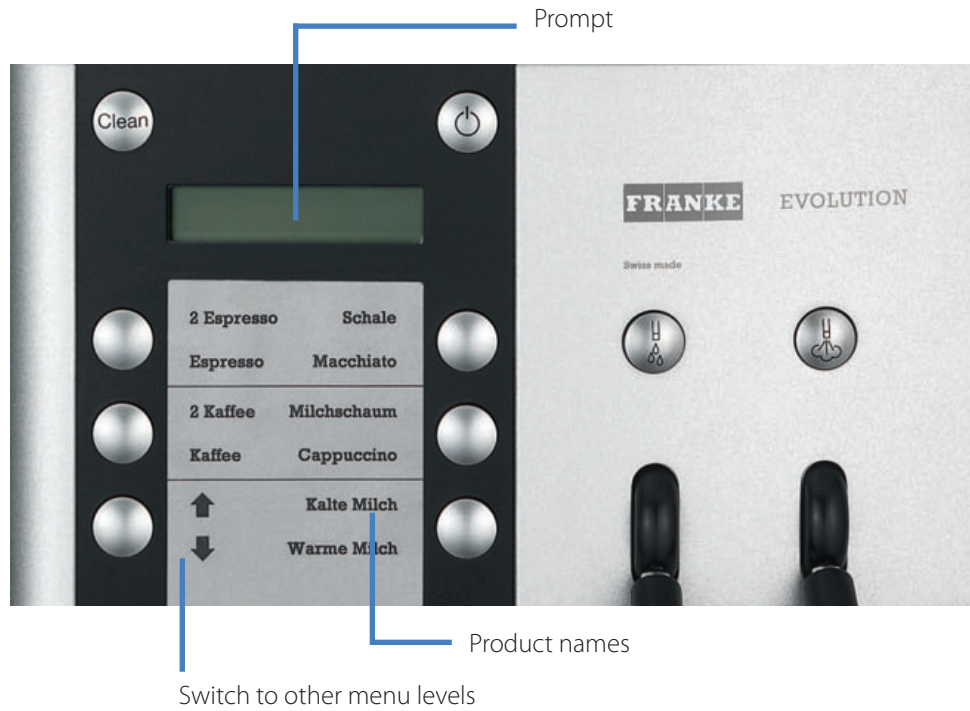

Add-on units

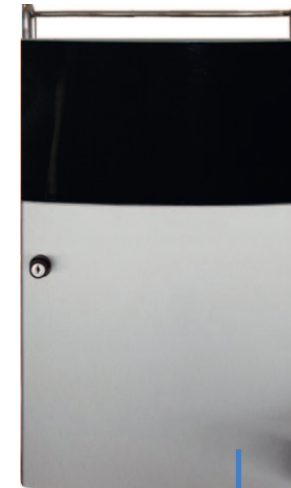

Refrigeration unit

(optional)

In many regions, milk is part of a good cup of coffee.

You can connect the milk cooler directly to the Evolution to make sure the milk does not spoil.

On/Off switch (behind door)



Cup Warmer (optional)

To enjoy coffee at its best, you need pre-heated cups.

The cup warmer fits perfectly on your Evolution.

On/Off switch

Installation and technical data

Your Evolution must be properly installed so that you can operate it correctly – one of our service technicians will do that for you. You'll have to take care of a few things first. You'll find the preparations for problem-free enjoyment of your coffee machine here.

Installation

Preparations

- The power connection for the coffee machine must be protected by a ground fault circuit interrupter (GFCI).
- Each terminal of the power supply must be able to be interrupted by a switch.
- The water connection must have a shut-off with a check valve and filter and must meet the requirements of the technical data.
- The water for the preparation of coffee should always be fresh, oxygenated and rich in minerals.
- If your Evolution has an electrical connection other than the one described in the table opposite, you will have received additional information regarding the installation with your order confirmation.

Installation

You must have completed these preparations before one of our service technicians can install the Evolution for you.

One of our service technicians will install your Evolution and put them into operation for the first time. The technician will walk you through the basic functions.

Technical data of Evolution

Coffee bean hopper	1.3 kg (2.9 lb) per grinder (optional: lockable)
Grounds container	50 cakes (optional: grounds ejection)
Boiler volume	small boiler: coffee 1.2 l 1.0 MPa (145 psi)
	large boiler: hot water/steam 1.6 l 0.2 MPa (29 psi)
Electrical connection	230 - 240 V 1 LNPE 2.2 kW 50/60 Hz Fuse: 10 A
	400 V 2 LNPE 5.2 kW 50/60 Hz Fuse: 16 A
Electric cable	l = 1800 mm (70 3/4")
Supply line	Metal hose with union nut G3/8", l = 1500 mm (59")
Waste-water hose	d = 16 mm (3/4"), l = 2000 mm (78 3/4")
	not permanently attached to the drain (vented)
noise emission	< 70 dB (A)
Weight	1M 46 kg (101.4 lb) 2M 50 kg (110.2 lb)
Cold water connection	G3/8" outside thread
Water pressure	80 - 800 kPa (0.8 - 8.0 bar or 11.6 - 116 psi)
water shut-off	with check valve and filter
water hardness	max. 70 mg CaO/l water (7 dH, 13 °fH)
Chlorine content	max. 0.1 mg/l (0.1 ppm)
Ideal pH value	7
Funnel	d = 50 mm (2") with siphon
Drain pipe	dmin = 1"
Ambient conditions	Humidity: max. 80%
	Ambient temperature: 10 - 35 °C (50 - 95 °F)

Dimensions

Front view

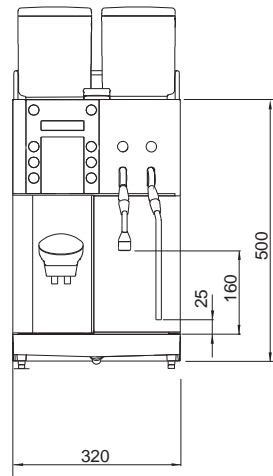

Side view

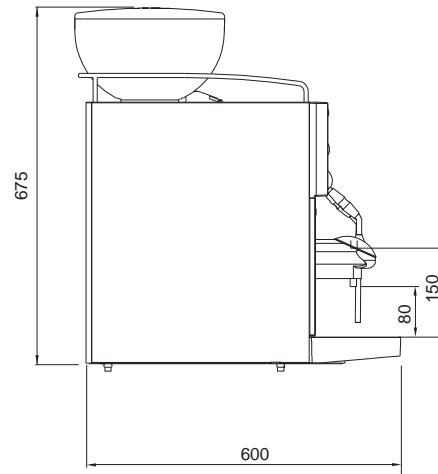

Top view

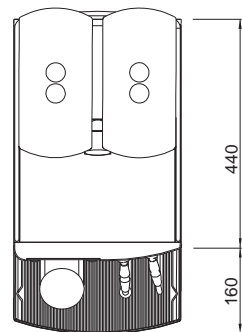

Cross-section from above (grommet hole)

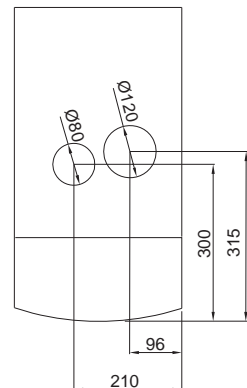

Adjustable feet (optional)

30 mm (1 ¼") foot	$675 \text{ mm (26 ½")} + 32 \text{ mm (1 ¼")} = 707 \text{ mm (27 ¾")}$
40 mm (1 ½") foot	$675 \text{ mm (26 ½")} + 45 \text{ mm (1 ¾")} = 720 \text{ mm (28 ¼")}$
70 mm (2 ¾") foot	$675 \text{ mm (26 ½")} + 70 \dots 80 \text{ mm (2 ¾"} \dots 3 ¼") = 745 \dots 755 \text{ mm (29 ¼"} \dots 29 ¾")}$
100 mm (4") foot	$675 \text{ mm (26 ½")} + 100 \dots 115 \text{ mm (4"} \dots 4 ½") = 775 \dots 785 \text{ mm (30 ½"} \dots 31")}$

Installation Dimensions

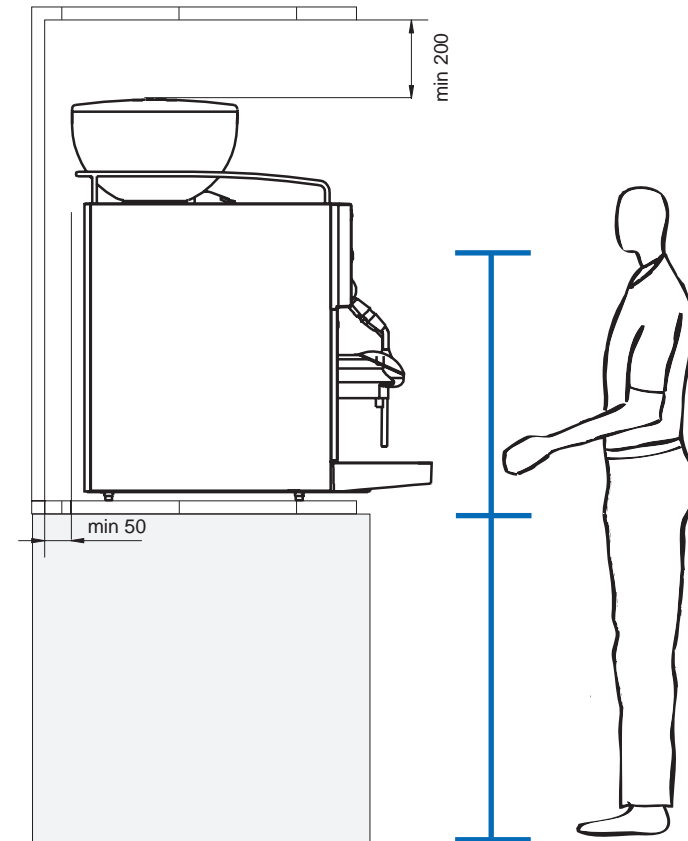

Prepare a stable, ergonomic surface (min. load capacity: 150 kg or 330.7 lb). The control panel should be at eye level.

Distance to the wall must be at least 50 mm (2"). Clearance above the machine must be at least 200 mm (7 ¾").

Adjustable feet can be used to compensate for unevenness or height differences.

If optional add-on units are installed, up to an additional 320 mm (12 ½") may be required per add-on unit.

Observe the connection requirements of the add-on units.

Technical data for the refrigeration unit

Milk container	10 liters (2.64 gallons)
electrical connection	200 - 240V 1LNPE 100W 50/60Hz Fuse: 10 A
	115V 1LNPE 100W 50/60Hz Fuse: 10 A
Electric cable	2000 mm (78 ¾")
Ambient conditions	Humidity: max. 80%
	Ambient temperature: 5 - 32°C (41 - 89.6°F)
Weight	approx. 26 kg (57 lb)
Width	320 mm (12 ½")
Depth	460 mm (18")
Height	500 mm (19 ¾")

Technical data for the cup warmer

Capacity	up to 80 cups (depending on cup size)
electrical connection	200 - 240V 1LNPE 140W 50/60Hz Fuse: 10 A
Electric cable	2000 mm (78 ¾")
Weight	approx. 15 kg (33 lb)
Width	225 mm (8 ¾")
Depth	440 mm (17 ¼")
Height	540 mm (21 ¼")

Adjustable feet (optional)

30 mm (1 ¼") foot	560 mm (22") + 32 mm (1 ¼") = 592 mm (23 ¼")
40 mm (1 ½") foot	560 mm (22") + 45 mm (1 ¾") = 605 mm (23 ¾")
70 mm (2 ¾") foot	560 mm (22") + 70...80 mm (2 ¾"...3 ¼") = 630...640 mm (24 ¾"...25 ¼")
100 mm (4") foot	560 mm (22") + 100...115 mm (4"...4 ½") = 660...675 mm (26"...26 ½")

Front view

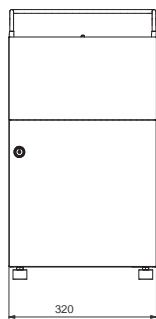

Side view

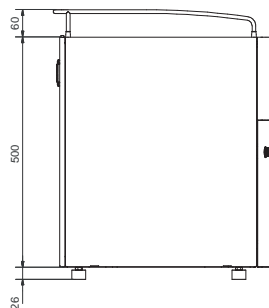

Top view

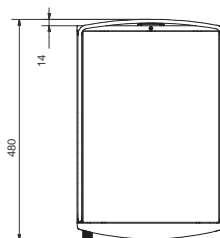

Installation Dimensions for Add-on units

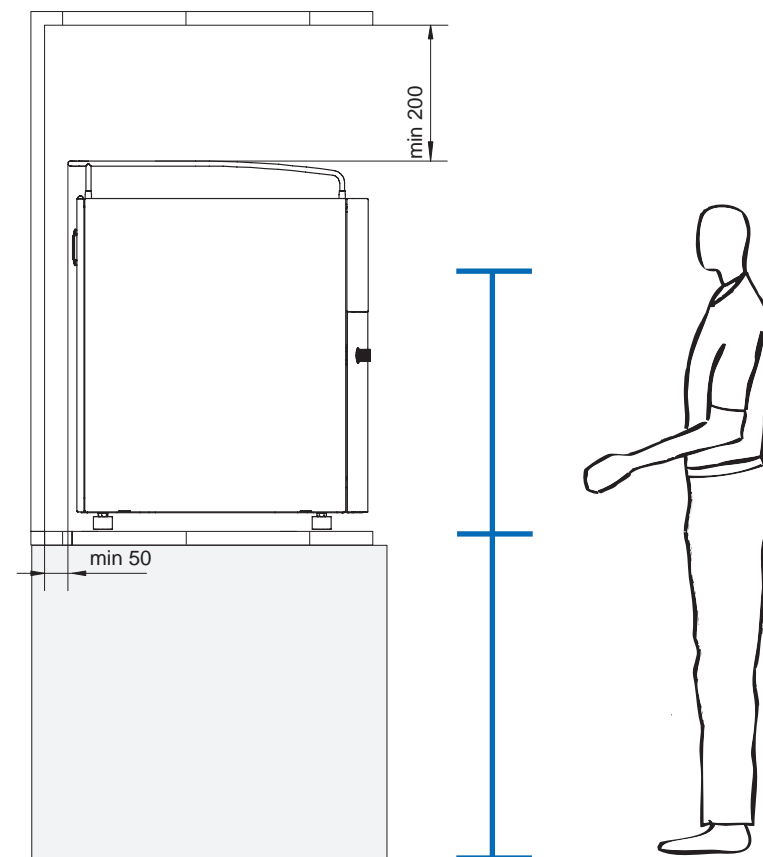

Place the optional add-on units in line with the Evolution and at eye level.

Distance to the wall must be at least 50 mm (2"). Clearance above the machine must be at least 200 mm (7 ¾").

Adjustable feet can be used to compensate for unevenness or height differences.

If optional add-on units are installed, up to an additional 320 mm (12 ½") may be required per add-on unit.

Start-up, Filling and Emptying

In this chapter you will learn how to start up your Evolution. In addition to the start-up procedure, you will learn about processes that take place automatically during start-up and about additional preparations. Get primed for a busy day!

Start-up of the Evolution

Daily start-up of the coffee machine

WARNING

Risk of scalding

from hot water, splatters and hot steam.

Do not touch the outlets or the area under the outlets. Point the steam wand downwards.

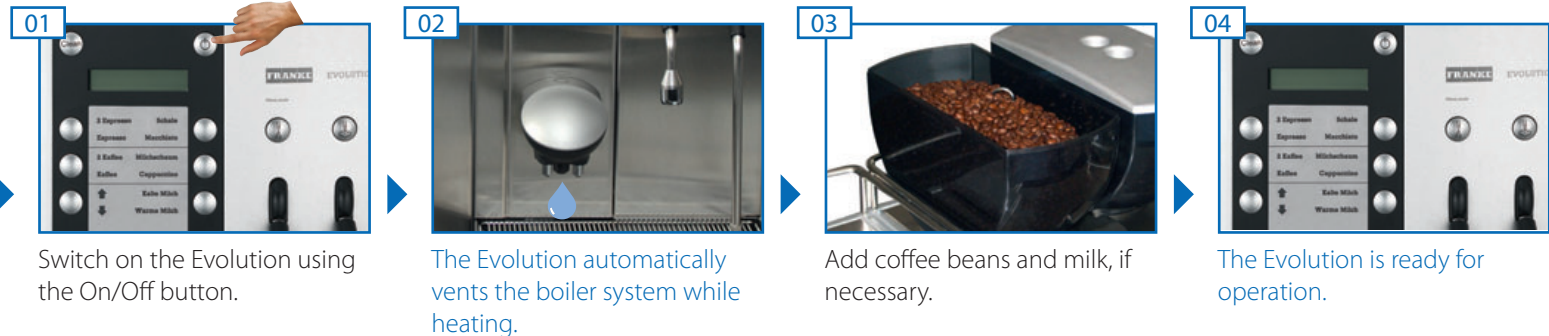

Filling the coffee bean hopper

WARNING

Risk of injury, eye injury and damage to the machine!

Objects in the coffee bean hopper or grinder may splinter and be ejected, leading to damage to the machine or injury.

Never put any objects in the coffee bean hopper or grinder. Never poke around in the coffee bean hopper or grinder with any object.



Emptying the grounds container

NOTICE

Formation of mildew due to coffee residue!

Empty and clean the grounds container at least once daily.



01 Open the grounds container door and remove the grounds container.



02 Empty, clean and dry the grounds container.



03 Replace the grounds container and close the grounds container door.

Emptying the coffee bean hopper



01 Slide the bean pusher inward to close off the coffee bean hopper.



02 Loosen fastening screw in the coffee bean hopper and lift the coffee bean hopper straight up.

NOTICE

The quality of the coffee may be impaired!

Dry the coffee bean hopper well after cleaning it. There must not be any residue from cleaning agents.



03 Empty, clean and dry the coffee bean hopper.



04 Place the coffee bean hopper on the Evolution and tighten fastening screw.



05 Pull the bean pusher out.

Start-up of the Refrigeration Unit (optional)



Open the refrigeration unit and switch it on with the On/Off switch.

Setting the temperature of the refrigeration unit (KE 320) (optional)



Thermostat

Temperature display

right button

Set button

left button



Milk quantity and temperature are monitored constantly.



Open refrigeration unit.



The thermostat is located in the refrigeration unit and can be set manually.

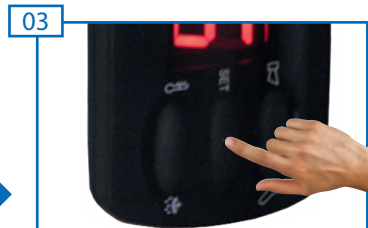

Press Set until the temperature is displayed.



Set the desired temperature using the left or right button.

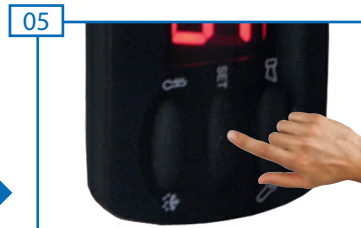

Press Set.
The temperature is set.

Filling milk (optional)



Instead of the milk container, you can also use bag-in-a-box containers or gallon containers. Milk quantity and temperature are monitored constantly.

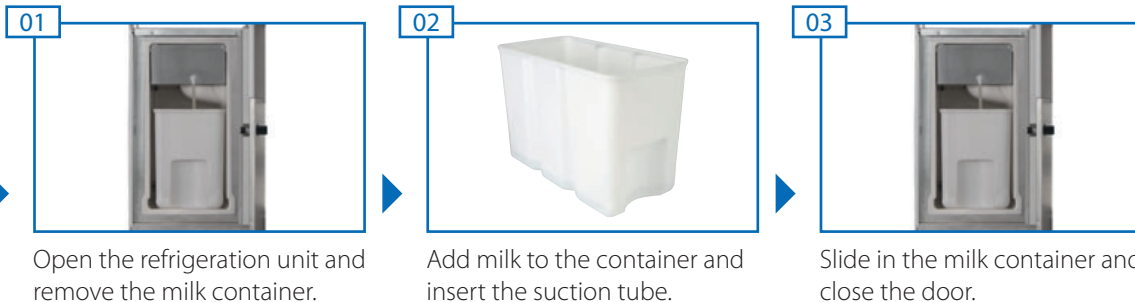

Emptying the refrigeration unit (optional)

NOTICE

The refrigeration unit may not be used to store milk!



CAUTION

Beware of spoiled milk!

If the machine is not cleaned regularly, milk residue may accumulate in the machine, clog the dispensers or find its way into drinks. Clean the Evolution and its add-on units daily.

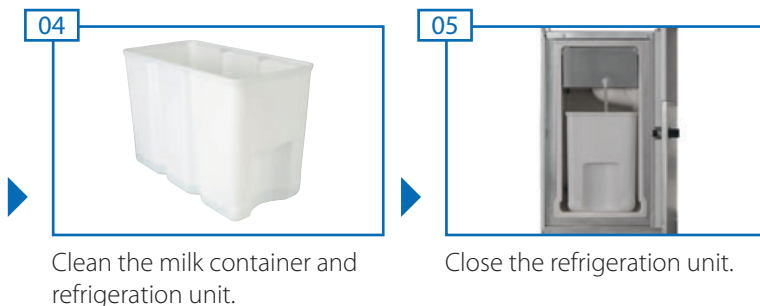

Preparing drinks

You chose the Evolution because you love coffee and promise your customers something special. You will find information about preparing drinks and the variations possible for your specialty drinks here.

Preparing a standard drink

WARNING

Risk of scalding or burning!

The dispensers and drinks are hot.

Only touch the outlets on the insulated handles.

Do not touch the area under the outlets.

In case of scalding or burns, immediately cool the affected area and, depending on the severity of the injury, consult a doctor.



01 Place a suitable cup or glass under the outlet



02 Set the outlet at the correct height.



03 Select menu level (if possible).



04 Press the product button desired.

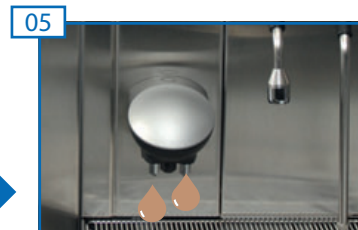

05 Preparation begins.



06 The drink is ready.

Drink preparation with preselection



You can preprogram up to 10 drinks per setting. Drink preparation with preselection must be enabled. Only an authorized service technician can enable preprogrammed settings.

Contact your service technician or FRANKE Kaffeemaschinen AG in Aarburg, Switzerland, directly.

WARNING

Risk of scalding or burning!

The dispensers and drinks are hot.

Only touch the outlets on the insulated handles.

Do not touch the area under the outlets.

In case of scalding or burns, immediately cool the affected area and, depending on the severity of the injury, consult a doctor.

Pay attention and work carefully.



Keep appropriate cups and glasses handy.



Set the outlet at the correct height.



Press the Product button. Preparation of the first drink is started.



Other drinks can be preselected while the current drink is being prepared.

WARNING

Risk of scalding!

The next drink starts automatically.

Pay attention and work carefully.



Preparation of the next drink starts immediately.

hot water dispenser

WARNING

Risk of scalding or burning!

The dispensers and drinks are hot.

Only touch the outlets on the insulated handles.

Do not touch the area under the outlets.

In case of scalding or burns, immediately cool the affected area and, depending on the severity of the injury, consult a doctor.



01 Place the appropriate cup or glass under the outlet.



02 Press the product button for hot water.
The drink is prepared.

Steam wand

WARNING

Risk of scalding or burning!

The dispensers and drinks are hot.

Only touch the outlets on the insulated handles.

Do not touch the area under the outlets.

In case of scalding or burns, immediately cool the affected area and, depending on the severity of the injury, consult a doctor.

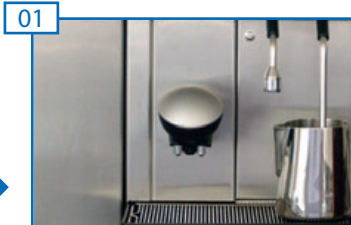

01 Place the appropriate cup or glass under the outlet.



The steam is drawn for as long as the time control was set or must be ended manually.



02 Press or hold the product button for steam.
Preparation begins.

Cleaning and Rinsing

Even a coffee machine like the Evolution must be cleaned at least once daily to ensure high-quality flavor.

Overview of the Separate Cleaning Instructions



Select the correct cleaning instructions for your system, taking the functions of your coffee machine into consideration.

	Evolution
Coffee machine with milk system (optional)	1T 312 562

Clean the water and steam nozzles



The steam and the water nozzles can be unscrewed. This makes cleaning limescale or dirt easier.

WARNING

Risk of burns

from hot outlets or nozzles.
▶ **Let the machine cool down.**
▶ **When the machine has cooled down, remove and clean the nozzles.**



01 Unscrew the nozzles and take them apart.



02 Clean the nozzles with a mild detergent and descale where necessary.



03 Put the nozzles back together and screw them back on.

Rinsing the coffee and milk systems manually



Rinsing is no substitute for daily cleaning!
Cleaning is necessary to prevent residue build-up in the coffee and milk areas!

WARNING

Danger of scalding

from hot water and steam.
▶ **Do not touch the outlets or the area under the outlets.**



01 Press Clean by double clicking. Clean menu is displayed.

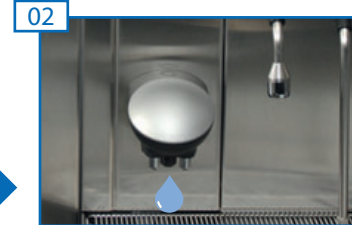

02 The Evolution rinses the coffee and milk systems.

Configuring your Evolution

Your Evolution can be programmed to suit your personal needs—so that the Evolution is just as flexible as you. We have kept the programming simple to make your job easier. Try it for yourself.

Controls and control concept



CLEAN button: Confirm/Save
Change cursor position

+/-: Change a value
Scroll through menu

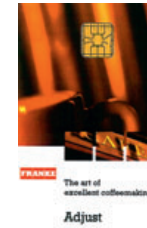

The Adjust card is used for:
Access restrictions
Modification of parameters
Storing saved settings

01

Insert the Adjust card into the card reader with the chip to the back.

02

The Customer menu appears on the display.

03

You can scroll through the menu with +/-.

04

Press CLEAN to confirm a selection.

05

With +/- you can set values.

Product definition

1 Product definition
2 Clock
3 Temperature
4 Accounting
5 Display
6 Error-Messages
7 View counters
8 Clear counters
9 Card service

1.1 Select Prod. Press product button desired	1.2 Fill level coffee Adjust fill level with +/-	1.3 Grind quantity left Adjust grind quantity with +/-
1.4 Grind quantity right Adjust grind quantity with +/-	1.5 Pre-Inject Adjust with +/-	1.6 Fill level milk Adjust fill level with +/-
1.7 Milk temp. Adjust temperature with +/-	1.8 Fill level foam Adjust fill level with +/-	1.9 Froth temp. Adjust temperature with +/-
1.10 Fill level hot w. Adjust fill level with +/-	1.11 Fill level cold w. Adjust fill level with +/-	1.12 Quantity of steam Adjust fill level with +/-
1.13 Auto steam temp. Adjust temperature with +/-	1.14 Pressure Adjust contact pressure with +/-	1.15 Price Adjust price with +/-

Clock, temperature and accounting

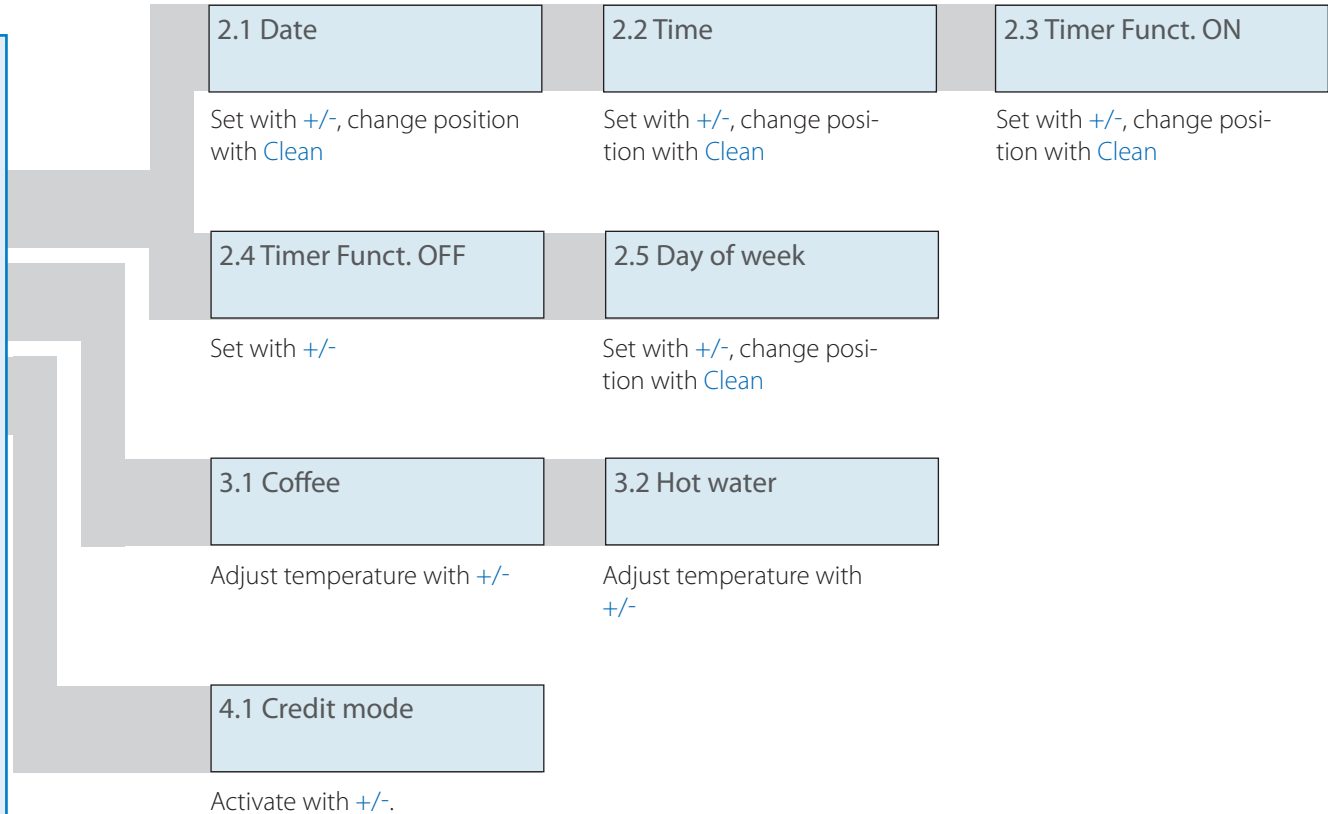
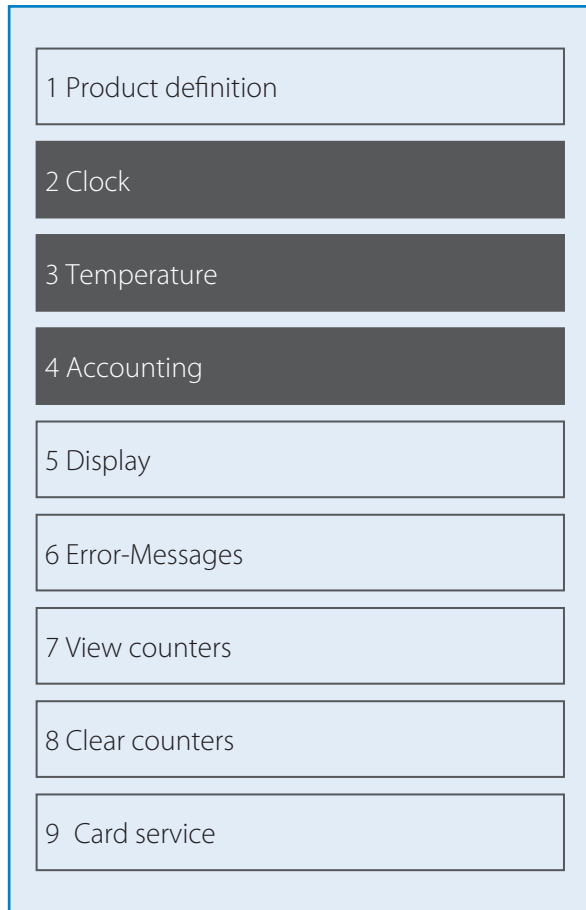

Display, Display errors, Display and delete counters, Card Service

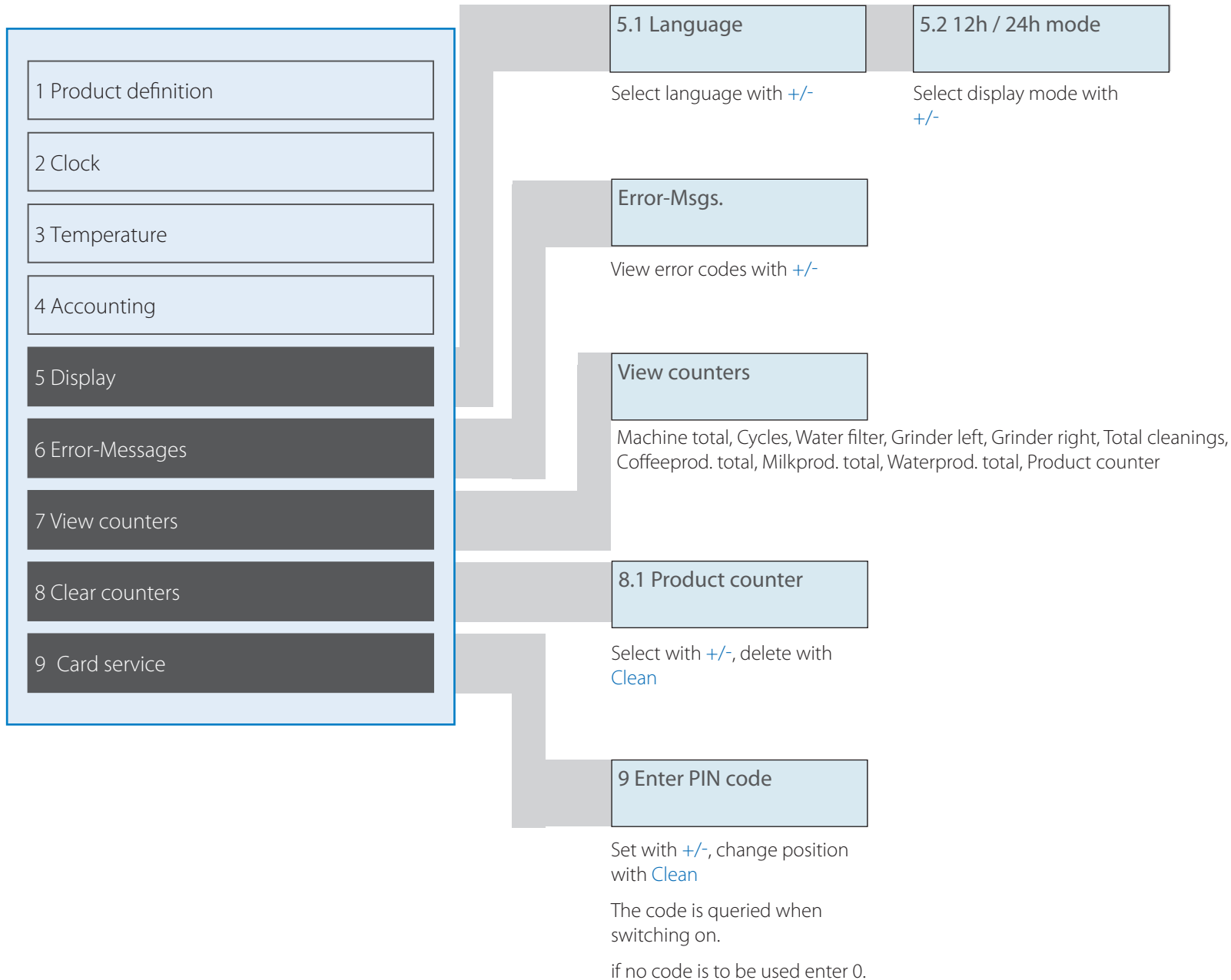

Shut-down and disposal

Do you want to shut down your Evolution for longer periods or take it out of service? Contact our service department. We recycle our coffee machines at a rate of nearly 100%, in order to protect the environment and resources.

Shut-down

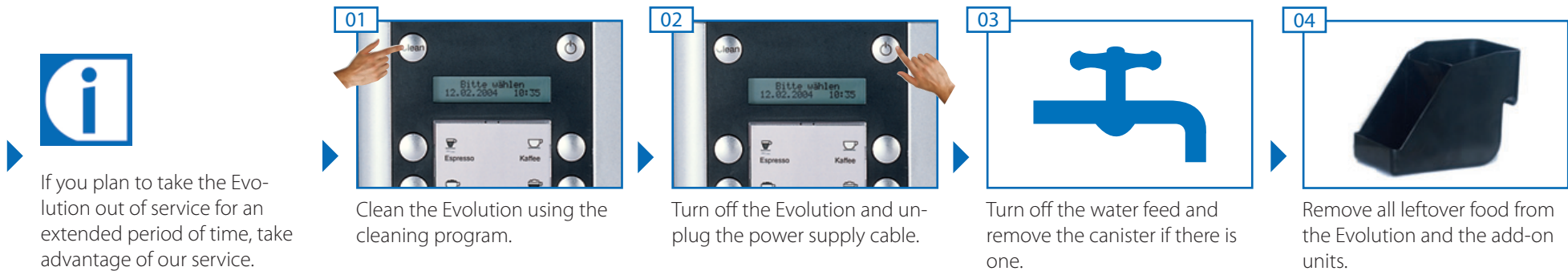

If you plan to take the Evolution out of service for an extended period of time, take advantage of our service.

Shut-down for longer periods and storage

NOTICE

Risk of damage to the machine!

Contact your FRANKE service team for proper storage.

Observe the storage conditions and drain your coffee machines.

Storage temperatures: +10 °C to +35 °C (50 °F to 95 °F)

Humidity: max. 80%

If you plan to start using your machine again later, taking advantage of our service is essential. The Evolution must be maintained and installed.

Proper functioning of the Evolution cannot be ensured otherwise.

disposal

Disposing of consumable materials

Observe local disposal regulations when disposing of consumable materials and waste.

Disposing of Evolution

You can return your Evolution directly to your retailer at no charge. We'll take care of the rest for you. For environmental protection reasons, we ask you not to dispose of the machine yourself.

Troubleshooting and Error Codes

If a problem occurs, your Evolution coffee machine will give you instructions. Error codes are displayed via the display screen. The table below shows how you can respond to these errors. Should you be unable to resolve a problem despite all best efforts, please contact our service department.

Help with Machine Errors

Error code	Text on machine display	Solution
2	Missing cof.outlet	Attach outlet and check that it is properly seated.
3	Door open	Close grounds container door.
10 to 19	Temperature sensor	Contact customer service.
22, 23	Heater timeout	Contact customer service.
30 to 32	Water supply	Contact customer service.
40 to 44	Motor timeout	Contact customer service.
50 to 60	Chipcard identify	Contact customer service.
99	Water filter	Contact customer service and schedule maintenance.
101	Grounds container full	Empty grounds container
105	Fresh/Waste tank	Only for versions with water tank: Empty or fill up tank.
110	Flowmeter	Switch the machine off and back on again. Contact customer service.
120	Out of beans	Add coffee beans.
130	No Milk	Add milk.

Help with problems concerning product quality

Tasteless coffee

Possible causes	Solution
Grind too coarse	Select a finer grind.
Too little powder	Increase amount of coffee.
Temperature too low	Increase temperature.
Coffee is too old	Store coffee properly.

Coffee tastes strange

Possible causes	Solution
Poor grind	Contact customer service.
Minimal coffee usage	Load smaller amount of coffee.
Coffee beans bad	Replace coffee beans.
Residual cleaning solution	Rinse the Evolution.
Cup dirty	Check dishwasher.
Water (chlorine, hardness, etc.)	Have water quality checked.

Coffee tastes bitter

Possible causes	Solution
Temperature too high	Decrease coffee temperature.
Grind too fine	Select a coarser grind.
Too little powder	Increase amount of coffee.
Roast too dark	Change coffee.

Coffee tastes sour

Possible causes	Solution
Temperature too low	Increase coffee temperature.
Roast too light	Change coffee.
Grind too coarse	Select a finer grind.

Certifications

Safety you can trust. Your Evolution coffee machine is not only among the most modern coffee machines in the world, it has also successfully passed safety inspections and tests for electromagnetic compatibility.

Declaration of conformity



FRANKE Kaffeemaschinen AG in Aarburg, Switzerland, certifies that the Evolution and its optional add-on units comply with the following standards. If you would like to see a copy of the original declaration of conformity, please contact FRANKE Kaffeemaschinen AG in Aarburg, Switzerland, directly.

The Evolution has been checked for compliance with the following standards:

EN 60335-1, EN 60335-2-14, EN 60335-2-15, EN 60335-2-64, EN 60335-2-75

Other standards that were applied:

EN 55014-1+A1+A2, EN 55014-2+A1, EN 50366+A1, EN 61000-3-2, EN 61000-3-3+A1+A2, IEC 62233, IEC 61000-3-2, IEC 61000-3-3+A1+A2, CISPR 14-1, CISPR 14-2:97+A1

The inspection was performed in accordance with the following directives:

73/23/EWG, 89/336/EWG, 93/68/EWG, 2006/42/EC



A

ADD-ON UNITS	
CUP WARMER	11
REFRIGERATION UNIT.....	11
ADJUSTABLE FEET.....	13
ADJUST CARD.....	8, 24

B

BOILER	9
--------------	---

C

CAPACITIES.....	10
CERTIFICATIONS	31
CLEANING.....	22
STEAM NOZZLE.....	23
WATER NOZZLE	23
CLEANING BRUSH	7
CLEANING BRUSHES	7
CLEANING INSTRUCTIONS.....	22
EVOLUTION	22
CLEANING SOLUTION	7
CLEANING TABLETS.....	7
COMMISSIONING	15
COFFEE MACHINE.....	15
REFRIGERATION UNIT.....	17
CONFIGURING.....	24
CONTROL PANEL.....	11
CUSTOMER MENU.....	24

D

DECLARATION OF CONFORMITY.....	31
DESCRIPTION OF MACHINE.....	10
DIMENSIONS.....	13
DISPOSAL	28
CONSUMABLE MATERIALS.....	28
EVOLUTION.....	28

E

ELECTRICAL CONNECTION.....	12
ELECTRICAL DATA.....	9
EMPTYING.....	16
COFFEE BEAN HOPPER	16
GROUNDS CONTAINER	16
REFRIGERATION UNIT.....	18
EMPTYING THE COFFEE BEAN HOPPER	16
ERROR CODES.....	29
EXPLANATION OF SYMBOLS	3

F

FILLING	15
COFFEE BEANS	15
MILK.....	18

H

HOT WATER DISPENSER	21
---------------------------	----

Franke Kaffeemaschinen AG
Franke-Strasse 9
4663 Aarburg – Switzerland

Telephone: +41 (0) 62 787 31 31
Internet: www.franke.com

Issued 03.2010 / order number: 1T 312 561 revision 0

