

Franke Kaffeemaschinen AG
Franke-Strasse 9
4663 Aarburg
Switzerland
Fon +41 62 787 36 07
Fax +41 62 787 30 10
www.franke.com

Franke Coffee Systems GmbH
Franke Strasse 1
97947 Grünsfeld
Germany
Fon +49 9346 9278 0
Fax +49 9346 9278 100
www.franke.de

Franke Coffee Systems
UK Ltd
18 Handley Page Way,
Old Parkbury Lane,
St Albans,
Hertfordshire AL2 2DQ
England
Fon +44 1923 635700
Fax +44 1923 635701
www.franke.com

Franke Coffee Systems
Americas
800 Aviation Parkway
Smyrna, TN 37167
USA
Fon +1 615 462 4265
Fax +1 615 462 4400
www.franke.com

Franke Japan Inc.
Amflat, 12-35-12
Nihonbashi Ningyocho, Chuo,
Tokyo 103-0013
Japan
Fon +81 3 5642 5880
www.franke.com

T 200

Straightforward, efficient and robust

EVERY ESPRESSO IS A PERFECT PLEASURE



19'328'657/11.13/CH-EN/Subject to dimensional, design and version changes.
visu! AG | Agentur für Identity und Kommunikation

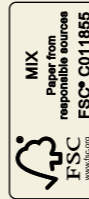



It's ease of use, choice of robust materials and high performance makes the T 200 the perfect choice for professional baristas. The classical and yet modern appearance of the retro-style Espresso machine is a real eye-catcher that goes with any room decor.

Giovanna Caruso
Caffè Da Graziella, Catania, Caffè Latte

ROBUST AND EFFICIENT

The T 200 is the straight forward all-rounder in the Franke Coffee Systems Traditional Line. It convinces thanks to its ease of use and latest technology components.



- 1 A CLEAN-CUT AFFAIR
- 2 INDIVIDUALLY PROGRAMMABLE
- 3 EFFECTIVELY ILLUMINATED
- 4 COMPACT



A CLEAN-CUT AFFAIR

The rust-proof stainless steel not only impresses with its modern aesthetics. The specially treated surface ensures fingerprints and water marks do not stand a chance. The drip tray is easy to remove and clean.



INDIVIDUALLY PROGRAMMABLE

The fill quantities per button can be programmed individually for each group.



EFFECTIVELY ILLUMINATED

The optional LED lighting makes the T 200 the highlight of every café or bar.



COMPACT

The T 200 Compact is exactly the right machine for every small café, bistro or bar to spoil the customer with perfect coffee pleasure. It may be small (W 540/D 530/H 520 mm), but it is in no way inferior to bigger machines: high performance due to 2 brewing groups, 2 steam dispensers and one hot water dispenser.

«DISCOVER, ENJOY
AND EXPERIENCE.»

FACTS & FIGURES

STANDARDS

- Semi-automatic Espresso coffee machine with 1, 2 or 3 brewing groups
- 2-group Compact Version
- Integrated pump
- Electrical heating system
- 3-liter boiler (for the 1-group version)
- 5-liter boiler (for the Compact version)
- 10-liter boiler (for the 2-group version)
- 15-liter boiler (for the 3-group version)
- Manometer for boiler and pump pressure control
- 1 hot water dispenser nozzle/2 steam valves for milk foaming (1-group only 1 steam valve)
- Electronic monitoring of filling and temperature control in the boiler
- Body made from rust-proof, stainless steel
- Narrow diameter filter, 53 mm, ideal for Espresso parameters (7 grams).

OPTIONAL

- LED lighting side
- Gas heating (for the 2- and 3-group versions)
- Electrical cup warmer
- (for the 2- and 3-group and Compact version).

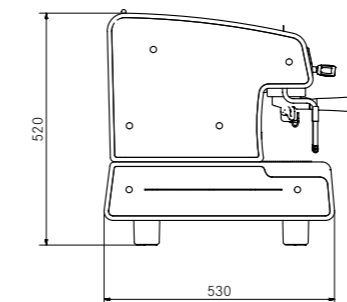
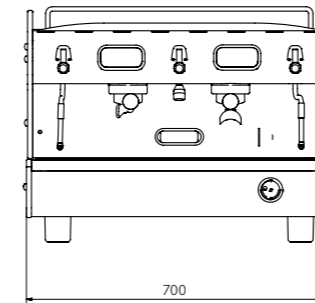

1 GROUP

Dimensions: WxDxH (mm)	460 x 530 x 520
Weight (kg)	42
Boiler capacity (litres)	3

2 GROUPS

Dimensions: WxDxH (mm)	700 x 530 x 520
Weight (kg)	65
Boiler capacity (litres)	10

3 GROUPS

Dimensions: WxDxH (mm)	930 x 530 x 520
Weight (kg)	82
Boiler capacity (litres)	15

T 200 COMPACT

Dimensions: WxDxH (mm)	540 x 530 x 520
Weight (kg)	57
Boiler capacity (litres)	5

CONNECTED LOAD AND HEATING CAPACITY

	1 GROUP	2 GROUPS	3 GROUPS	T 200 COMPACT
Volt	100/220/240	220/240	220/240/400	110/220/240
Hz	50/60	50/60	50/60	50/60
W	3000	3600	6500	3000/3800

Please check country specific product availability as these may vary.